

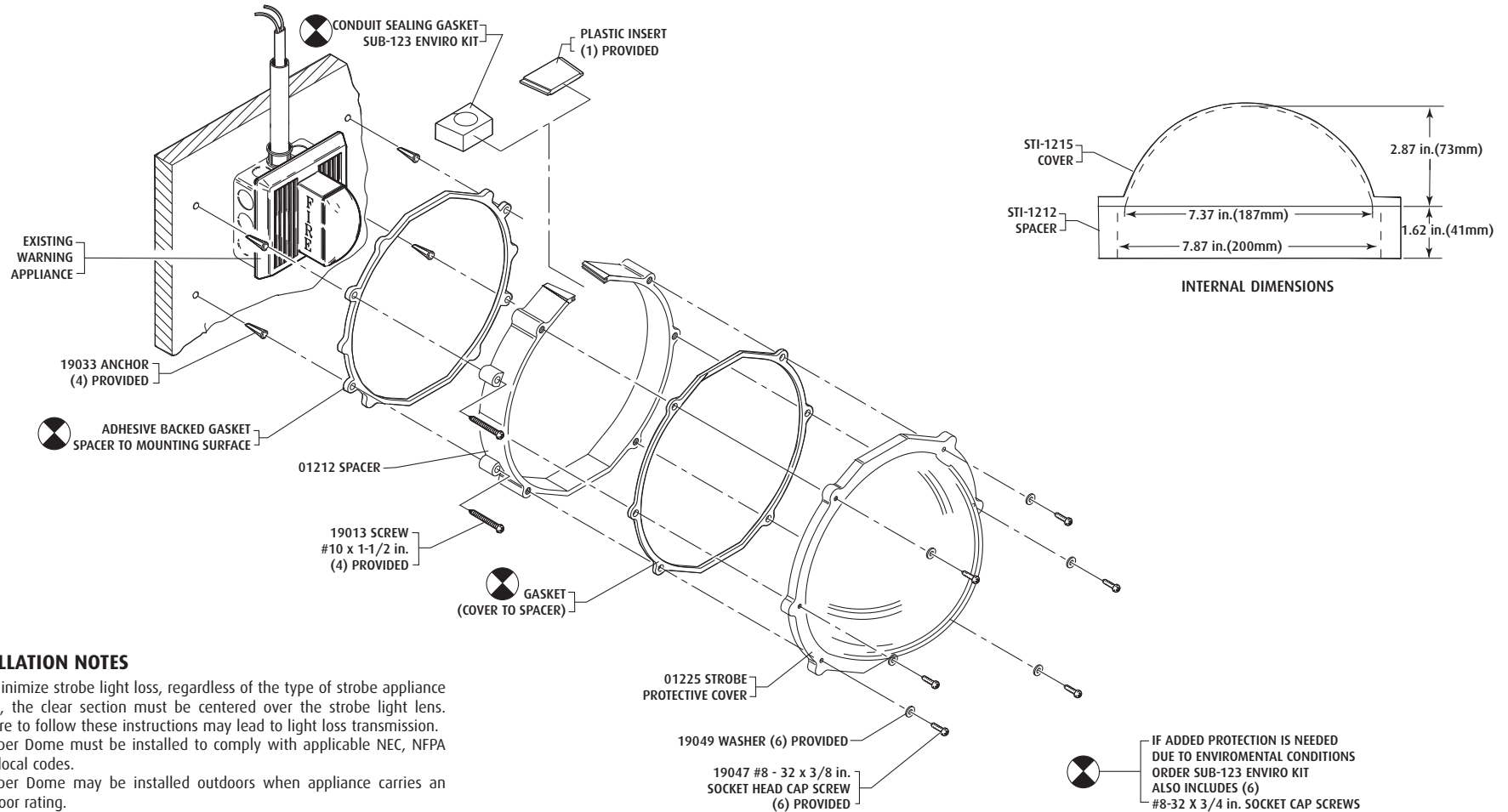

**Safety Technology International, Inc.**  
 2306 Airport Road • Waterford, Michigan 48327-1209  
 Phone: 248-673-9898 • Fax: 248-673-1246  
 Toll Free: 800-888-4784 • E-mail: info@sti-usa.com  
 Web: www.sti-usa.com

**Safety Technology International (Europe) Ltd.**  
 Unit 49G Pipers Road • Park Farm Industrial Estate • Redditch  
 Worcestershire • B98 0HU • England • Tel: 44 (0) 1527 520 999  
 Fax: 44 (0) 1527 501 999 • Freephone: 0800 085 1678 (UK only)  
 E-mail: info@sti-europe.com • Web: www.sti-europe.com



### INSTALLATION NOTES

1. To minimize strobe light loss, regardless of the type of strobe appliance used, the clear section must be centered over the strobe light lens. Failure to follow these instructions may lead to light loss transmission.
2. Stopper Dome must be installed to comply with applicable NEC, NFPA and local codes.
3. Stopper Dome may be installed outdoors when appliance carries an outdoor rating.
4. If added protection is needed due to environmental conditions, order SUB-123 Enviro kit.

### INSTALLATION INSTRUCTIONS - REFER TO EXPLODED VIEW

1. Using cover as a template, place against mounting surface at proper location according to NFPA 72.
2. Mark and drill (6) holes 3/16 in. (4.7mm) diameter, 1 in. (25mm) deep.
3. Insert the (6) anchors into the wall.
4. Install strobe appliance.
5. Install cover with washers and screws.
6. Test appliance according to appliance manufacturer's instructions.

### CLEANING INSTRUCTIONS

Rinse with water to remove abrasive dust and dirt. Wash with soap or mild detergent, using a soft cloth (do not scrub). Rinse once more then dry with a soft cloth or chamois. To remove grease or wet paint, rub gently with a cloth wetted with naphtha. Then wash and rinse. DO NOT USE RAZOR BLADES.

## INSTALLATION OF STI-1227 STOPPER® DOME FOR STROBE

All specifications and information shown were current as of publication, and are subject to change without notice.

1227IS APRIL2006



## UL INSTALLATION REQUIREMENTS STI DOME SERIES

### CAUTION:

- The enclosure is rated to protect signaling appliances indoors and in areas of indirect weather exposure. The cover may be used outdoors only with devices also suitable for outdoor use.
- When covering fire-signaling appliances with this enclosure, some light and sound loss occurs. Please follow the guidelines listed during installation.
- Strobe light loss values for respective manufacturers are shown below. To determine the new composite candela value for use with this guard refer to the sample calculation shown below for a manufacturer's strobe.
- Example: Record the manufacturer's candela value as "A" and the light loss value as "B" and the assembly value as "C". For example "Sample Company" has a 60 candela strobe with a 30% light transmission loss value. Value "A" is now 60. Value "B" is (60 times 30% or 0.30) in this case 18. Now value "C" equals value "A" minus value "B" or 60-18 = 42 candela light source. Now refer to NFPA tables for proper room size that the newly established value "C" will work in. Submittal installation drawings must show the composite candela value as 42.
- On a dual value strobe such as 15/75 a calculation must be done for each value and the drawing notation composite value for each number on the strobe.

### Performance Review - LIGHT DERATING FACTOR

MANUFACTURER	SERIES	STI-1215/1217/1219	STI-1225/1227/1229
ADT SECURITY	ADTG1-V SERIES	20%	32%
AMSECO	SL24W-153075	22%	37%+
AMSECO - COLORED LENSES	SL24W-153075 A, B, G, OR R	22%	37%+
AMSECO - COLORED LENSES	SL24C-3075110 A, B, G, OR R	22%	37%+
AMSECO - COLORED LENSES	CSL24W-A, B, G, OR R	22%	37%+
AMSECO - COLORED LENSES	CSL24C-A, B, G, OR R	22%	37%+
DETECTION SYSTEMS	GES24 SERIES	27%	37%+
DETECTION SYSTEMS	GES24-15/75	27%	37%+
EST / EDWARDS	2440S SERIES	33%	34%+
EST / EDWARDS	202 SERIES	33%	34%+
EST / EDWARDS	G1-V SERIES	20%	32%+
EST / EDWARDS	G1-HV SERIES	20%	32%+
EST / EDWARDS	G1-HOV SERIES	20%	32%+
EST / EDWARDS	EG1-V SERIES	20%	32%+
EST / EDWARDS	EG1-HV SERIES	20%	32%+
EST / EDWARDS	EG1-HOV SERIES	20%	32%+
FARADAY LLC	2700	23%	33%+
GENTEX	GES24 SERIES	27%	37% +
GENTEX	GES24-15/75	27%	37% +
HARRINGTON SIGNAL	GES24 SERIES	27%	37% +
HARRINGTON SIGNAL	GES24-15/75	27%	37% +
HONEYWELL	XLSG1-V SERIES	20%	32%+

MANUFACTURER	SERIES	STI-1215/1217/1229	STI-1225/1227/1229
HONEYWELL	XLS202 SERIES	35%	34%+
HONEYWELL	XLSG1-HV SERIES	20%	32%+
HONEYWELL	XLSG1-HOV SERIES	20%	37%+
MIRCOM	FS-240	22%	37%+
MIRCOM	MS SERIES	33%	34%+
MIRCOM	MG1-V SERIES	20%	32%+
MIRCOM	MG1-HV SERIES	20%	32%+
MIRCOM	MG1-HOV SERIES	20%	32%+
MIRTONE	MG1-V SERIES	20%	32%
NATIONAL TIME & SIGNAL	GES24 SERIES	27%	37%
NATIONAL TIME & SIGNAL	GES24-15/75	27%	37%+
POTTER ELECTRIC	AS-24-153075R	22%	37%+
POTTER ELECTRIC	AS-24-153075W	22%	37%+
SECUTRON	GES24 SERIES	27%	37%+
SECUTRON	GES24-15/75	27%	37%+
SIEMENS	202 SERIES	33%	34%+
SIEMENS	G1-V SERIES	20%	32%+
SIEMENS	U-MCS SERIES	23%	33%+
SYSTEM SENSOR	SS24110ADA	26%	36%+
SYSTEM SENSOR	P2, PC2, P4, PC4, SX, SC	39%	28%
WHEELOK	RSS-24MCW	34%	31%
ZITON PTY LTD	ZG1-V SERIES	20%	32%+

+ Indicates notification appliance can also be used with STI Heater Domes models STI-1229HTR or STI-1229HTR240.

**SOUND DERATING FACTOR for STI-1215, STI-1217, STI-1219**  
**HORNS: Amseco Audible Horn Sounders: 6.2 dBA; System Sensor: 3.1 dBA**  
**SPEAKERS: Siemens Adapter Series (0.5, 1, or 2 watt taps only): 4.1 dBA**