

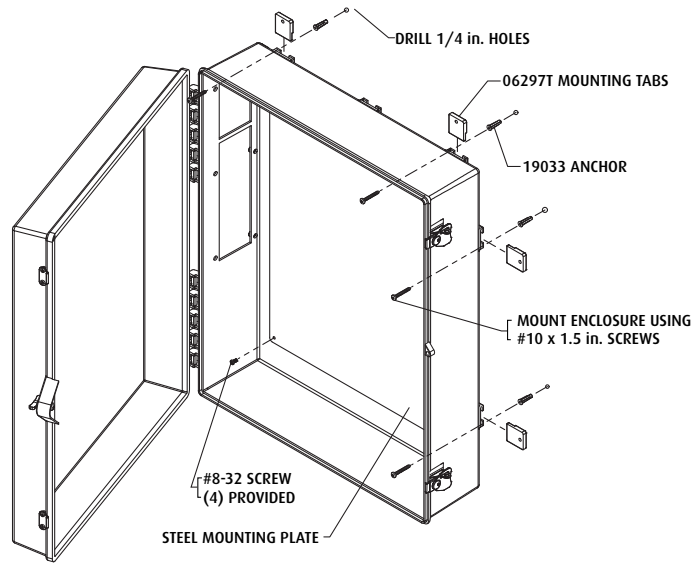

Safety Technology International, Inc.
 2306 Airport Road • Waterford, Michigan 48327-1209
 Phone: 248-673-9898 • Fax: 248-673-1246
 Toll Free: 800-888-4784 • E-mail: info@sti-usa.com
 Web: www.sti-usa.com

Safety Technology International (Europe) Ltd.
 Unit 49G Pipers Road • Park Farm Industrial Estate • Redditch
 Worcestershire • B98 0HU • England • Tel: 44 (0) 1527 520 999
 Fax: 44 (0) 1527 501 999 • Freephone: 0800 085 1678 (UK only)
 E-mail: info@sti-europe.com • Web: www.sti-europe.com



VIEW 1

Install Cabinet:

1. Install all Mounting Tabs
2. Place Enclosure in position
3. Mark and drill 1/4" diameter holes
4. Insert #10-12 anchors
5. Mount Enclosure using #10 x 1.5 screws

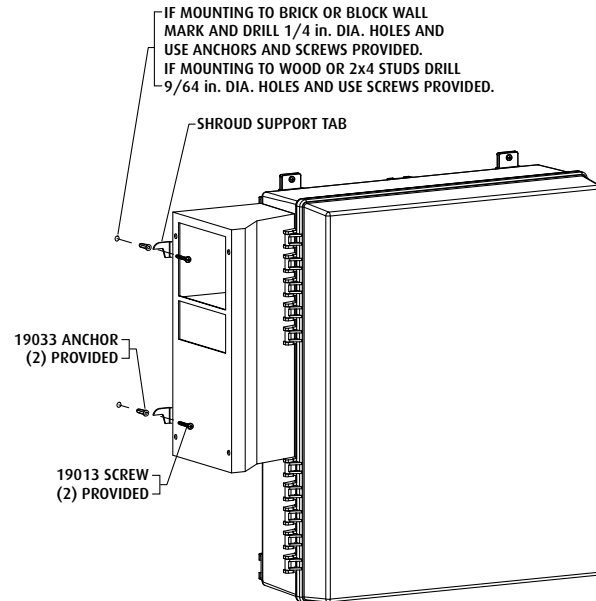

VIEW 2

Locate and Mark Holes for Shroud Support Tabs:

1. Place shroud against enclosure cutouts and insert the two top 1/4-20 Socket Head Cap Screws. Hand tighten only.
2. Mark hole locations for the shroud support tabs as shown in View 2.
3. Remove shroud from enclosure and drill holes for shroud support tabs. (See View 2 notes.)
4. Insert anchors and screws. Thread screws in, leaving approximately 1/8" gap between mounting surface and screw head. The shroud support tabs should rest on the screws.

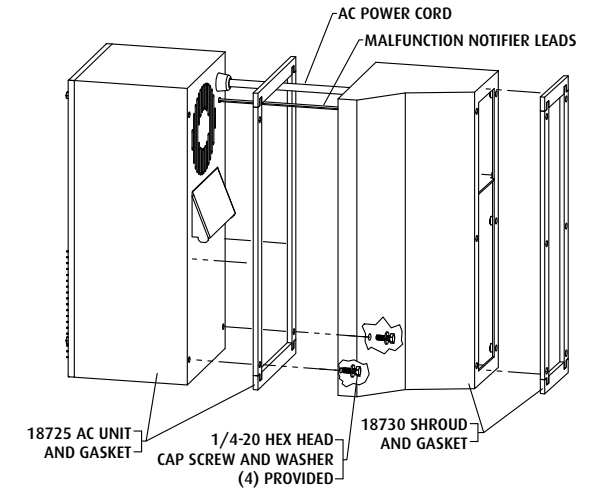

VIEW 3

After 7550 Enclosure has been Mounted:

1. Remove adhesive backing and apply AC gasket to AC unit.
2. Place AC power cord and malfunction notifier leads through upper opening of shroud.
3. Mount AC unit to shroud using the (4) 1/4-20 hex head screws and washers. Thread all four hex head screws into AC unit from inside shroud. Hand tighten only until all four screws are in place.
4. Now tighten with 7/16 open end wrench.
5. Remove adhesive backing and apply shroud gasket to shroud.

INSTALLATION OF STI-7550AC ENCLOSURE

All specifications and information shown were current as of publication and are subject to change without notice.

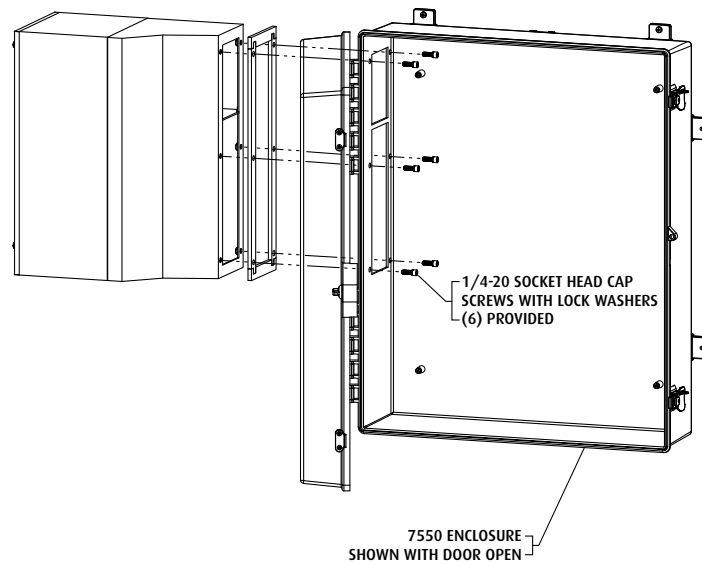

VIEW 4

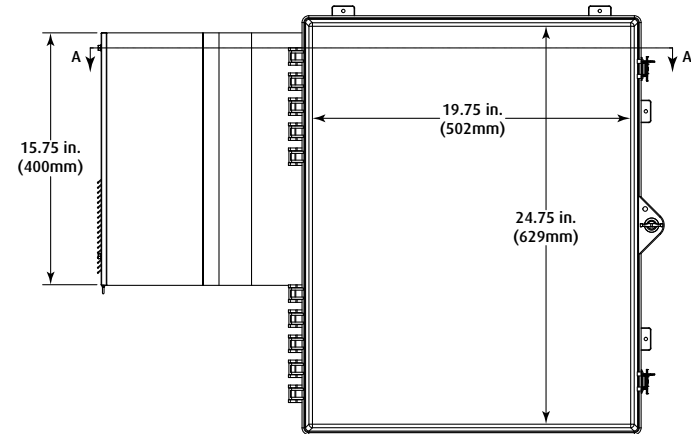
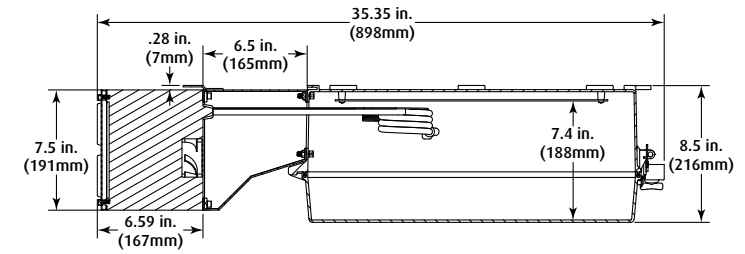

VIEW 5

Mount AC Unit and Shroud Assembly to Enclosure using the (6) 1/4-20 Socket Head Cap Screws and Lock Washers Provided

1. Insert AC power cord and malfunction notifier leads through top opening of enclosure cutout.
2. Place AC unit and shroud assembly against enclosure cutouts and rest the shroud support tabs on the two screws previously placed. This will help support the weight of the AC unit.
3. Install all (6) 1/4-20 socket head cap screws and lock washers through enclosure into shroud. Hand tighten only.
4. Now tighten using 3/16" Allen wrench.
5. After AC unit and shroud assembly has been installed, install steel mounting plate to the back inside wall of enclosure using the (4) #8-32 screws provided. (Refer to View 1)

INSTALLATION OF STI-7550AC ENCLOSURE

All specifications and information shown were current as of publication and are subject to change without notice.