

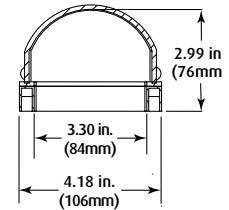

Safety Technology International, Inc.
 2306 Airport Road • Waterford, Michigan 48327-1209
 Phone: 248-673-9898 • Fax: 248-673-1246
 Toll Free: 800-888-4784 • E-mail: info@sti-usa.com
 Web: www.sti-usa.com

Safety Technology International (Europe) Ltd.
 Unit 49G Pipers Road • Park Farm Industrial Estate • Redditch
 Worcestershire • B98 0HU • England • Tel: 44 (0) 1527 520 999
 Fax: 44 (0) 1527 501 999 • Freephone: 0800 085 1678 (UK only)
 E-mail: info@sti-europe.com • Web: www.sti-europe.com

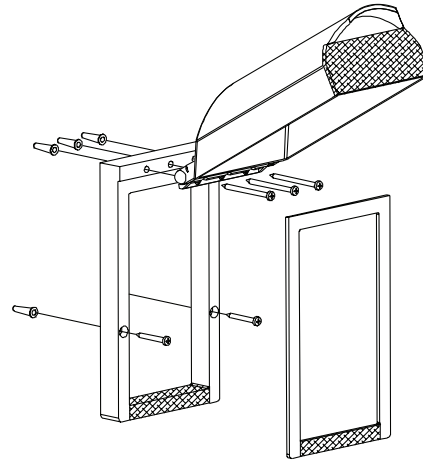
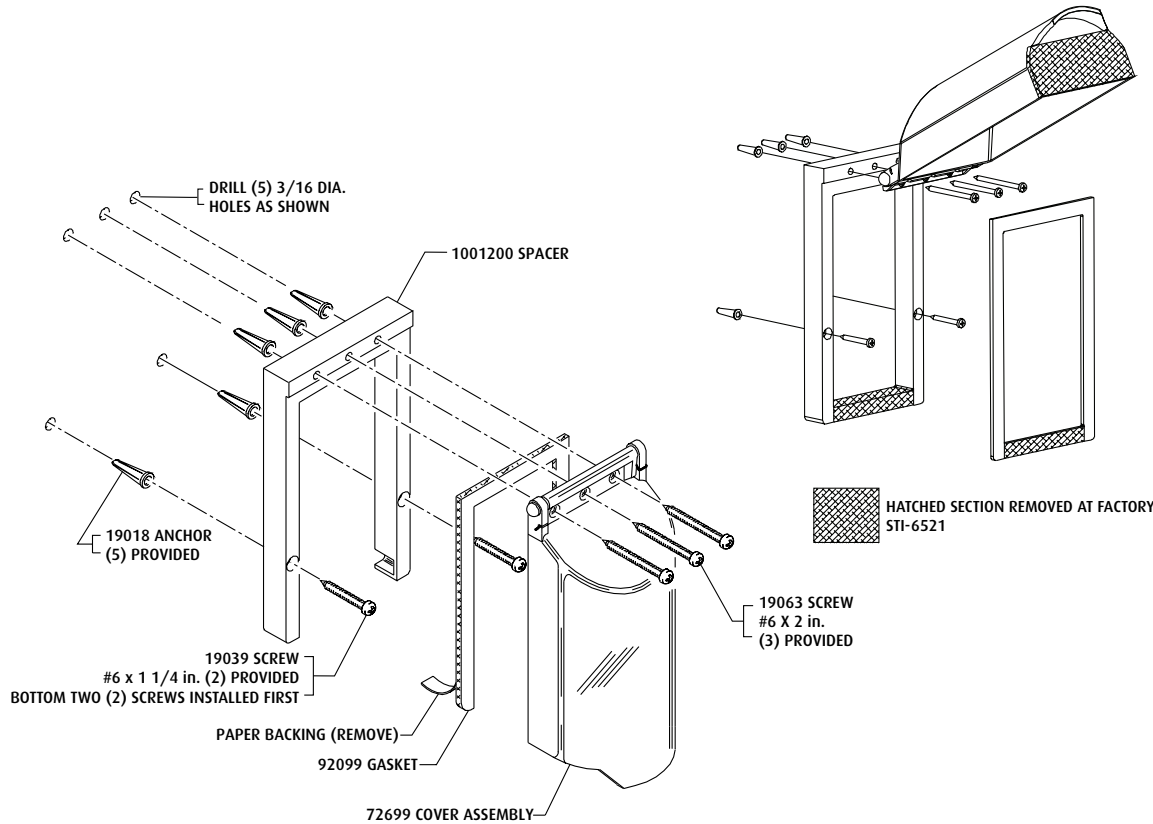

**END VIEW
 STI-6522**

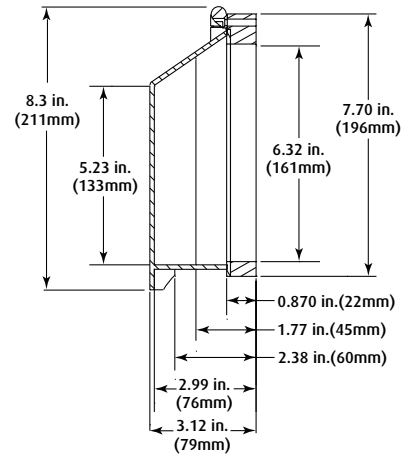

**SIDE VIEW
 STI-6520
 STI-6521**

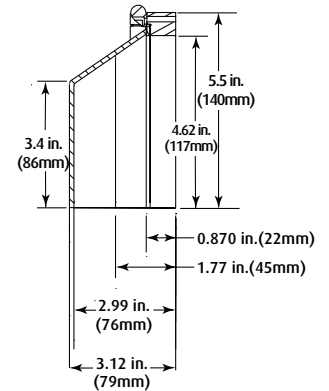

**SIDE VIEW
 STI-6522**

INSTALLATION INSTRUCTIONS

1. Using the spacer as a template, mark and drill (5) 3/16 dia. holes.
2. Install the (5) anchors and fasten the (2) bottom screws of the spacer.
3. Remove backing paper from gasket and place gasket on spacer with bottom of gasket aligned with bottom of spacer.
4. Install the cover assembly with the (3) remaining hinge screws.

CLEANING INSTRUCTIONS

1. Rinse cover with water to remove abrasive dust and dirt.
2. Wash with soap or mild detergent using a soft cloth. (DO NOT SCRUB.)
3. Rinse once more, then dry with a soft cloth or chamois.
4. To remove grease or wet paint, rub gently with a cloth wetted thoroughly with naphtha, then wash and rinse. (DO NOT USE RAZOR BLADES.)

INSTALLATION OF STI-6520, STI-6521 and STI-6522 BOPPER STOPPER®

All specifications and information shown were current as of publication and are subject to change without notice.