

**Installation Procedure
for the
SL-2107, SL-2307 & SL-2407**

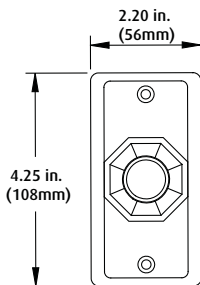

PRODUCT DIMENSIONS



**FRONT
VIEW**

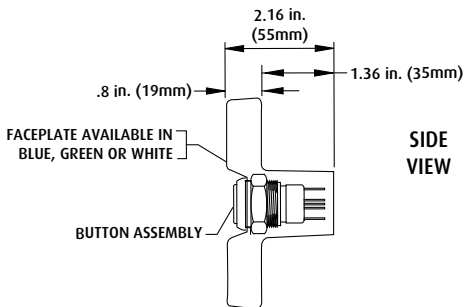

**SIDE
VIEW**

FACEPLATE INSTALLATION

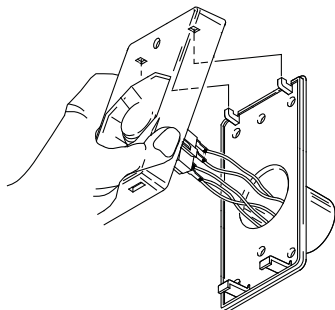

STEP 1

PLACE THE TWO LOCATING TABS INTO THE TWO TOP SLOTS OF THE FRONT HOUSING AND ROTATE DOWNWARD AS SHOWN. FRONT HOUSING SNAPS INTO PLACE.

FACEPLATE REMOVAL

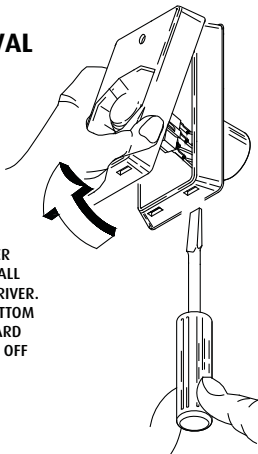

STEP 2

GRASP FRONT COVER WHILE USING A SMALL FLATHEAD SCREWDRIVER. PLACE INTO THE BOTTOM SLOTS, PRESS UPWARD AND ROTATE COVER OFF AS SHOWN.

WIRING DIAGRAM

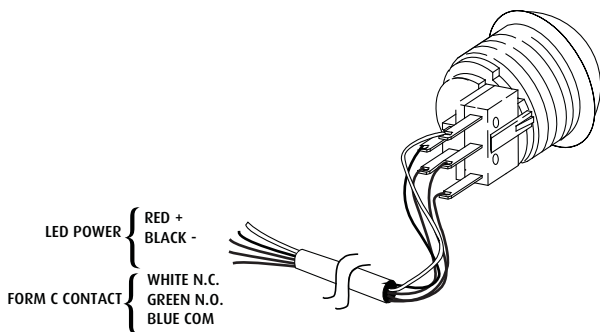

CONTACT RATING - 30 VDC, 5 AMP

CONTACT CONFIGURATION - SPDT MOMENTARY CONTACT

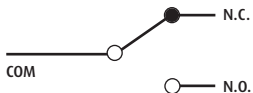

LAMP REPLACEMENT

STEP 1

GRASP SWITCH HOLDER ASSEMBLY AS SHOWN. USING OTHER HAND ROTATE BUTTON 1/4 in. CLOCKWISE AND SEPARATE THE TWO PIECES. PULL LAMP STRAIGHT OUT.

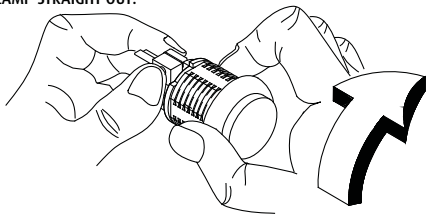

STEP 2

INSERT NEW LAMP AND COMPLETE INSTALLATION AS SHOWN ABOVE BUT ROTATE COUNTER-CLOCKWISE TO LOCK THE PIECES TOGETHER.

REPLACEMENT LED	PIN
12 VDC RED	10132
12 VDC BLUE	10136
24 VDC RED	10131
24 VDC BLUE	10135

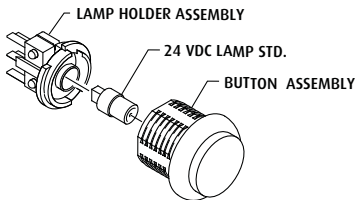

INSTALLATION PROCEDURE DIRECTLY TO SINGLE GANG

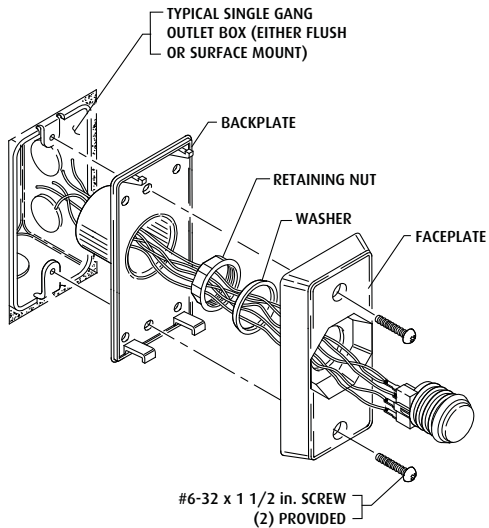

INSTALLATION PROCEDURE DIRECTLY TO WALL OR DOOR CASING

STEP 1

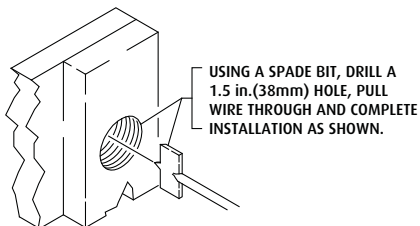

STEP 2

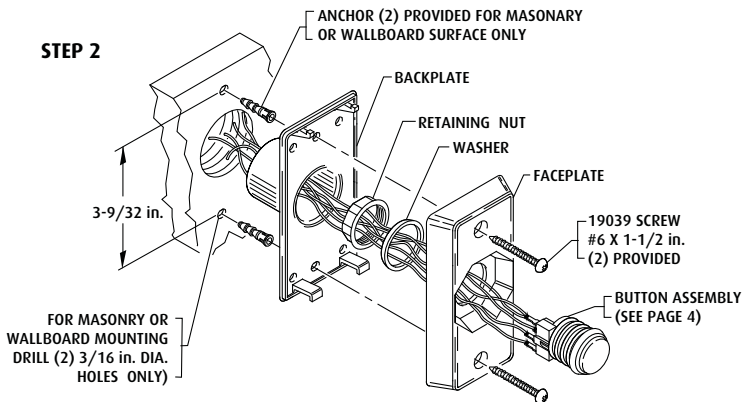



Safety Technology International, Inc.

2306 Airport Rd • Waterford, MI 48327
Phone: 248-673-9898 • Fax: 248-673-1246
info@sti-usa.com • www.sti-usa.com

Safety Technology International (Europe) Ltd.

Unit 49G Pipers Road • Park Farm Industrial Estate • Redditch
Worcestershire • B98 0HU • England • Tel: 44 (0) 1527 520 999
Fax: 44 (0) 1527 501 999 • Freephone: 0800 085 1678 (UK only)
E-mail: info@sti-europe.com • Web: www.sti-europe.com