

STI Stopper® Station Slim Line



SL-2107

PRODUCT OVERVIEW

Now there is a way for buttons to be mounted in small areas where space is limited. These ADA Compliant, multipurpose buttons incorporate a unique slim and narrow design that helps dramatically where space is a minimum. The button does not require an electrical box, which allows it to be placed in areas not large enough for normal sized buttons. The Stopper Station Slim Line could be used for an exit door, access control or as an emergency power off button, to name a few of the possible applications.

Some examples of custom labels include: “exit”, “push to exit”, “push to open”, “push to close”, “call for help”, “push to turn off”, or “power off”. Custom labeling limited to two lines of eight characters each.

Because of the Stopper Station Slim Line button's superior design combined with quality construction throughout, you can expect outstanding performance for years to come.

FEATURES

- Button fits in small, narrow areas such as on a door frame.
- Has a momentary illuminated push button.
- Standard 24 VDC LED or a 12 VDC version is also available upon request.
- Uses long-life LED.
- Plastic collar protects switch contacts.
- Housing unit color choices include: blue, green or white.
- Form “C” contact rating 30 VDC 5 amps.
- Includes a 5 conductor lead wire for easy connection.
- Standard illuminated momentary button is blue for blue shell and red for other shells.
- Custom labeling available. Limited to two lines, eight characters each.
- Easy installation.
- Three year guarantee against breakage of polycarbonate in normal use (one year on electro mechanical and electronic components).

STI Stopper® Station Slim Line

Dimensions and Technical Information

MODELS AVAILABLE

- SL-2107 Stopper Station Slim Line - Momentary Illuminated - green
- SL-2307 Stopper Station Slim Line - Momentary Illuminated - white
- SL-2407 Stopper Station Slim Line - Momentary Illuminated - blue

NOTE: Custom labeling available. Limited to two lines, eight characters each.

APPROVALS & WARRANTY

TESTING

- Meets ADA operational requirements

WARRANTY

Three year guarantee against breakage of polycarbonate in normal use (one year on electro mechanical and electronic components).

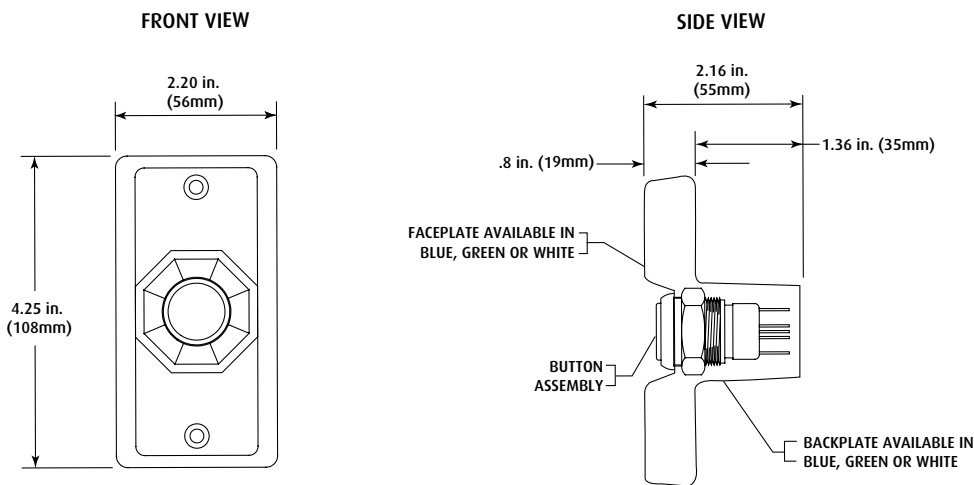

Safety Technology International, Inc.

2306 Airport Road
Waterford, Michigan
48327, USA

Tel: 248-673-9898
Fax: 248-673-1246
Tollfree: 800-888-4784
info@sti-usa.com
www.sti-usa.com

Unit 49G Pipers Road
Park Farm Industrial Estate
Redditch, Worcestershire
B98 0HU England

Tel: 44 (0) 1527 520 999
Fax: 44 (0) 1527 501 999
Free: 0800 085 1678 (UK)
www.sti-europe.com